

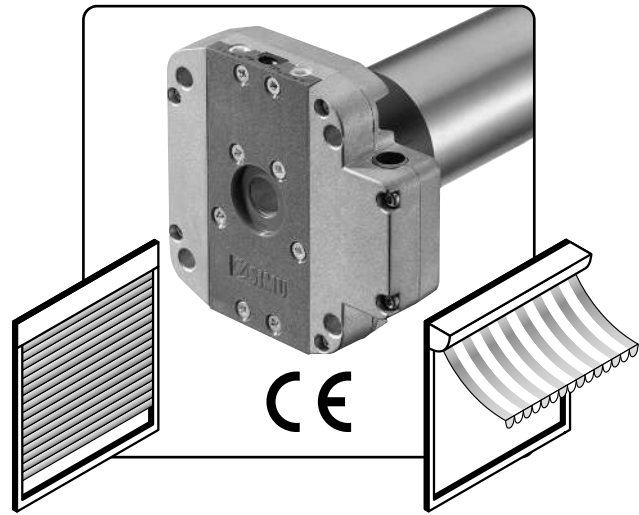

DMI 5 - DMI 6
230V/50HZ - 120V/60HZ

1311.F - 09/02



S.A.S. au capital de 5 000 000 € - Z.I. Les Giranux - BP71 - 70103 Arc-Les-Gray CEDEX
 RCS GRAY B 425 650 090 - SIRET 425 650 090 00011 - n° T.V.A CEE FR 87 425 650 090

		mm			
		A	B	C	D
DMI 5 230V-50 Hz Ø/T mini = 47	508-17 510-17 515-17	574	5	26	4,2
	520-17 525-17 530-17 535-17 540-17 550-12			—	—
	515-18 525-18 510-12 520-12 530-12			26	4,2
DMI 5 120V-60 Hz Ø/T mini = 47	535-18 540-12 550-12	644	—	—	—
	640-17 655-17 670-17 685-17 660-12 680-12 6100-12 6120-12 T660-14 T680-14 T6100-14	660	5	36	8
	—			—	—

